

FERRUM PROCESS SYSTEMS USED EQUIPMENT

The patented D-ACT pusher centrifuge could be delivered **within one month** of ordering. The used equipment comes with all modifications that have resulted from the testing **at no extra charge**.

D-ACT® PUSHER CENTRIFUGE PD-60

Year 2019
Machine Trailmachine

 Filtrate
 Solids

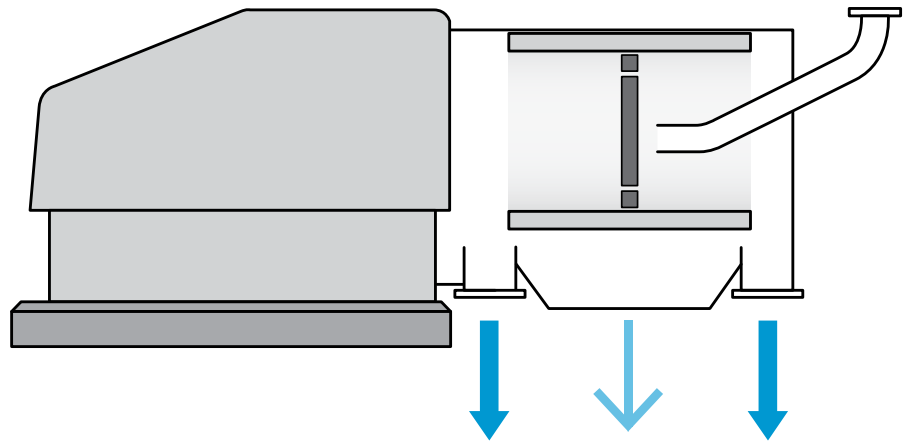

HIGHER THROUGHPUT

80% higher throughput than traditional pusher centrifuges



ENERGY SAVINGS

Save 20% on energy costs with D-ACT



COMPACT DESIGN

Reduced footprint thanks to compact design



PARTICLE SUITABILITY

Suitable for applications with medium to large particle size



ENHANCED PROTOTYPE

Prototype with all the enhancements



QUICK AVAILABILITY

Lead time 1 month

D-ACT® PUSHER CENTRIFUGE PD-60

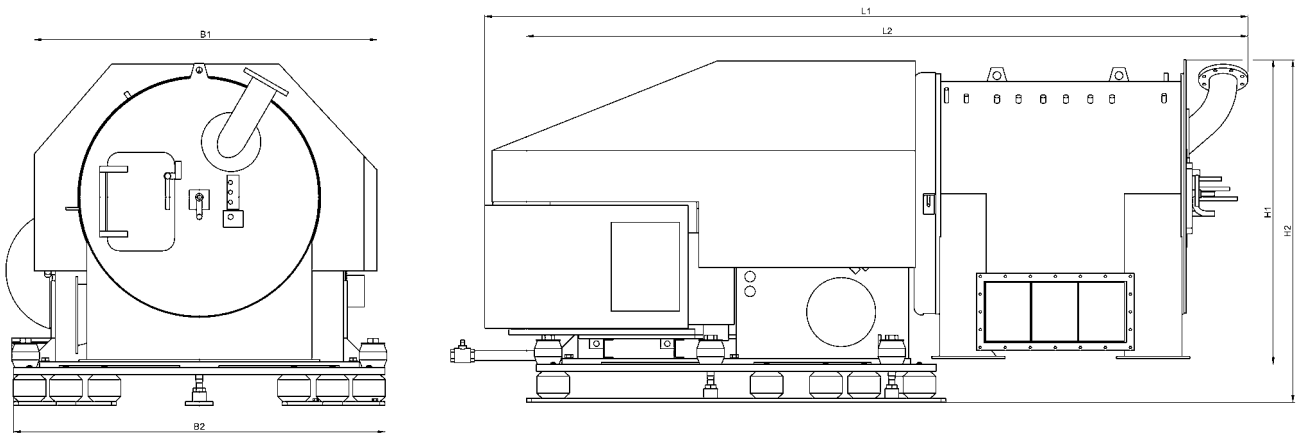

Dimensions	mm
L1	3100
L2	3500
B1	1500
B2	1700
H1	1250
Height with vibration isolation and concrete counterweight	2000
Height with vibration isolation and steel counterweight	1550
Height with vibration isolation, without counterweight	1450

Technical Data

Basket diameter	630 mm
Number of stages	1
Max. rotor speed	1390 min ⁻¹
Max. number of strokes	95 min ⁻¹
Max. G force	690 g
Operating weight (with oil filling, without counterweight)	4900 kg
Maximum NaCl throughput (dependent on feed conditions)	50 t/h



INTERESTED?

Send your request to check the suitability of the D-ACT for your application

► prch.sales@ferrum.net