

CANNING TECHNOLOGY
CO₂ EXHAUST UNIT
FERRUBASIC CAN SEAMER OPTION

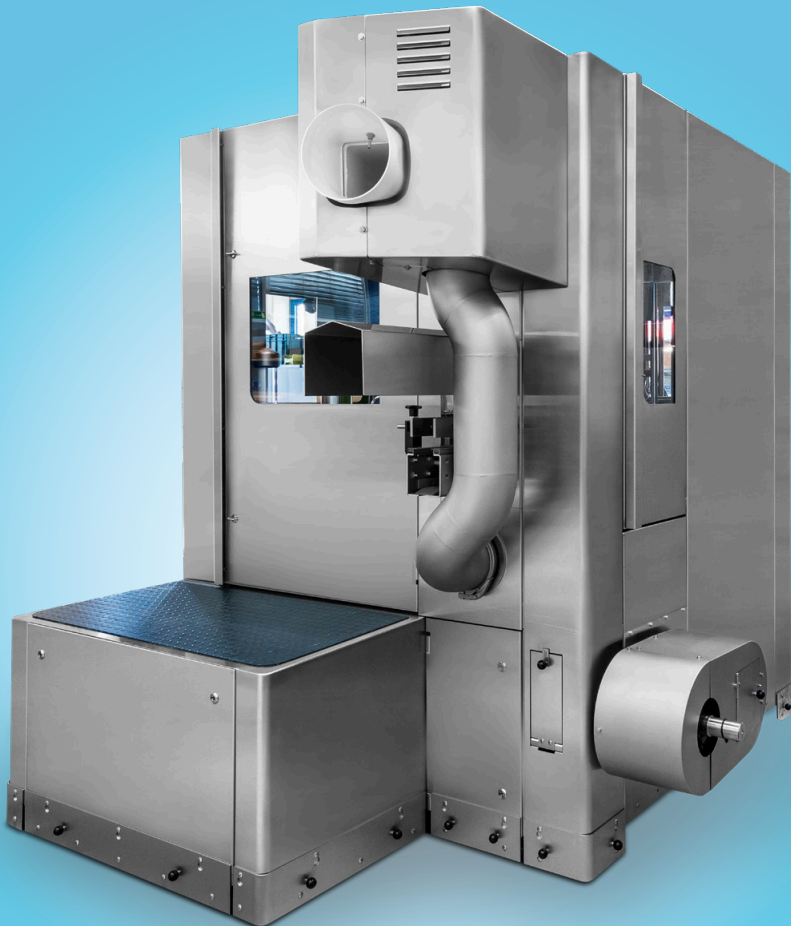

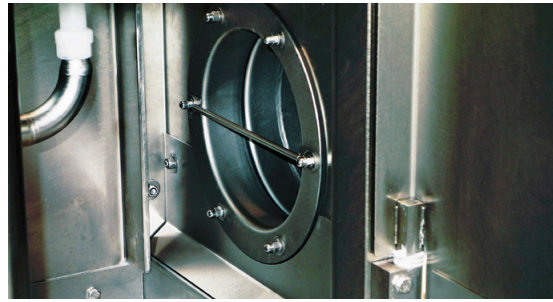
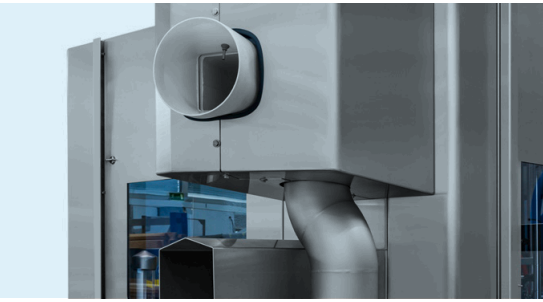

Benefits for the customer

- + Compliance with higher hygiene standards
- + Efficient and effective exhaust
- + Greater pressure at the ventilator outlet
- + Low MAK* values around the seamer
- + Effective cleaning
- + Available as an upgrade for ferruBasic can seamer

* Maximum workplace concentration

Features

- + Integrated washing device connection
- + Simple disassembly of the suction pipe thanks to quick-release ring
- + Stainless steel ventilator enclosure
- + 0.37 kW motor (50/60 Hz operation possible)
- + Inert gas welded stainless steel suction pipe

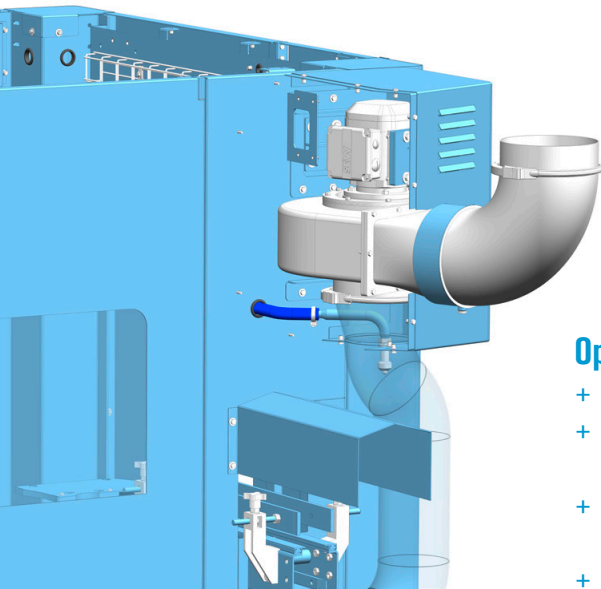

Options

- + Collection tray under bubble breaker
- + Ultrasonic bubble breaker (up to 15% CO₂ savings)
- + Pressure monitoring switch (guarantees process reliability)
- + Manual stop unit

Ferrum Packaging Ltd | Industriestrasse 11 | 5503 Schafisheim | Switzerland
T +41 62 889 13 11 | packaging@ferrum.net | www.ferrum.net

Technical changes are reserved.
09/22 / EN / KLS / A / (©) Ferrum Packaging Ltd